



欢迎

欢迎来到飞利浦世界！您能选择和购买飞利浦的产品，我们非常高兴。您可以在我们的官方网站上获得飞利浦公司的全方位技术支持，如：使用手册、软件下载、保修信息等。

www.philips.com

产品特点

本产品采用精密的光学结构设计，以及专业的音视频处理技术。具有超清画质，色彩还原度高，拾音准确等特性，适用于商务视频协作、远程教学、网络直播等领域，产品特点如下：

- 采用全高清玻璃镜头，有效像素达200万。
- 1/2.9英寸优质CMOS传感器。
- 图像清晰、流畅，分辨率达1080P/30fps。
- 水平视角范围达88°。
- 支持自动白平衡，宽动态。
- 2.88mm焦距。
- 支持标准USB2.0接口，即插即用。

安全信息

在使用和操作设备前，为确保设备性能最佳，并避免出现危险或非法情况，请遵循各项电气安全规定和适用的法律。

注意

- 请避免在震动或存在安全隐患的环境下使用产品。
- 高处安装产品时，请确保产品固定牢固。
- 请勿自行拆解或改装产品。
- 请勿将镜头对准强光，否则会损坏图像传感器。

您的设备

设备包含

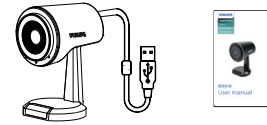

主机预览

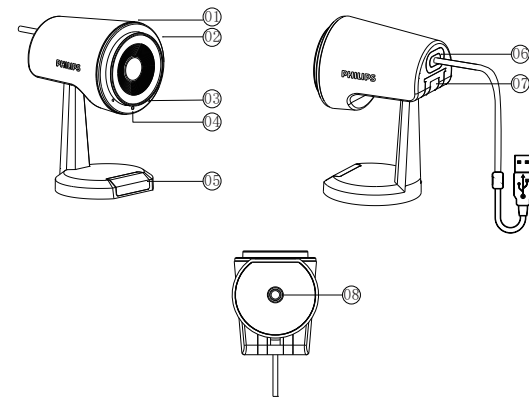

- | | |
|---------|----------|
| ① 塑胶外壳 | ⑬ 硅胶防滑垫 |
| ② 镜头装饰件 | ⑭ USB电源线 |
| ③ 麦克风 | ⑮ 旋转轴 |
| ④ 指示灯 | ⑯ 螺母 |

设置说明

产品安装

底部埋置螺母，可更好配合外接支撑架：

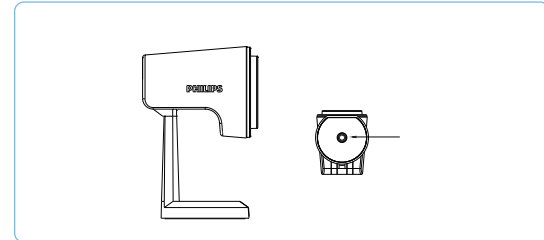

摄像头可按需求调整到合适角度，方便拍摄更优质画面：

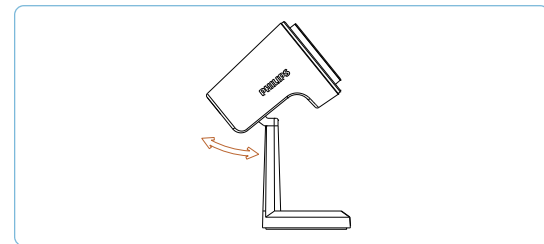

安装在不同厚度的载体上使用：

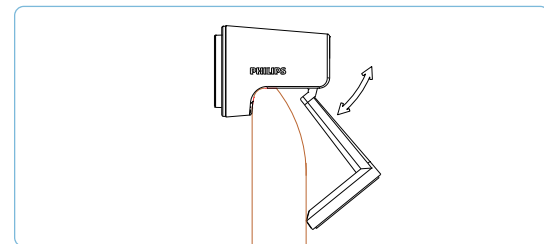

扩展使用

- PSE0510单独使用时可以和电脑通过有线方式配合使用。
- PSE0510可与PSE0400通过有线方式配合使用。

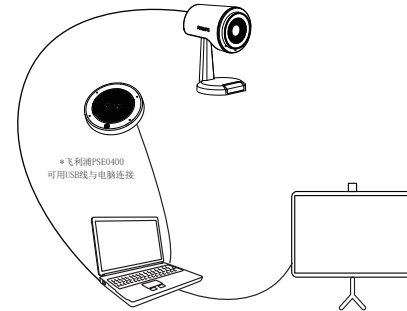

温馨提示

- 获取PC端视讯软件请登录并下载路径：
download.szgps.net/SmartMeeting/SmartMeeting.exe
- 了解更多使用操作，请访问：
<http://www.jwd-dvr.com/service/download.html>

Service Service Service GUARANTEE

This guarantee card is valid in china
This guarantee card should be owned by
The USER
此保用卡在中国适用，用户请保留此卡。



此产品是一件设计精良，有高品质原件制造之数码产品，在正确使用及保养下应能正确地表现其优越性能。
自购买日期始，整机保修一年。关于主要部件保修期限，按照国家消费法规定执行。多功能视讯设备中国区总经销（深圳市京华数码科技有限公司）将按下列保用条款持卡用户提供免费保修服务。

保用条例：

保用服务只限于一般正常使用下有效。一切人为损坏，例如接入不当电源，使用不当配件，不依说明书使用，因运输及其他意外而造成之损坏，非经本公司认可之维修和改装，用于商业及工业目的造成产品损坏，错误使用或疏忽而造成损坏，不当之安装或因天灾造成损坏等，保用服务立刻失效。此保用服务并不包括附件，辅助装置，运输费。维修时请带上此卡及正本发票。

User's Name:	Model No:
用户姓名.....	型号.....
Address:	Serial No:
地址.....	机身编号.....
Tel.No:	Product Place:
电话.....	产地.....
Post Code:	
邮编.....	
Company Seal:	Shop name and address:
购买商品印章.....	购买商名称及地址.....
Date of Purchase:	Invoice No:
购买日期.....	发票号.....
	Tel.No/Post Code:
	电话/邮编.....

产品服务热线：400 800 7890



Specifications subject to change without notice.

Trade marks are the property of Royal Philips or their respective owners.

© 2021 Speech Processing Solutions GmbH. All rights reserved. Philips and the Philips' shield emblem are registered trademarks of Koninklijke Philips N.V. and are used by Speech Processing Solutions GmbH under license from Koninklijke Philips N.V. All trademarks are the property of their respective owners.
Document version 1.0, 2021-5-11



Welcome

Welcome to the world of Philips! We are delighted that you choose and buy Philips products. You can have access to full set of technical support on Philips official website, such as user manuals, software downloads, and guarantee information, etc.

www.philips.com

Product Features

With precise optical structure design and professional audio and video processing technology, the device possesses the characteristics of ultra clear image quality, high color revivification degree and accurate pickup, and is suitable for business video, distance learning, live network and other fields. The product features are as follows:

- Full HD glass lens with 2 million effective pixels.
- High quality 1/2.9 inch CMOS sensor.
- Clear and smooth image with a resolution of 1080P/30fps.
- Support auto focus adjustment.
- The range of horizontal view is up to 88°.
- Support auto white balance, wide dynamic.
- The focal length of 2.88mm.
- Support standard USB2.0 interface, plug-and-play.

Safety Information

Please abide by all regulations and applicable law on electric safety when using and operating this equipment in order to ensure the best performance of the equipment and avoid dangers or illegal situations.

Notice

- Avoid using products in situations of vibration or hidden danger.
- When installing products at height, make sure the products are fixed solidly.
- Do not disassemble or modify products by yourself.
- Do not focus the lens on the strong light, otherwise the image sensor will be damaged.

Your device

What's in the box

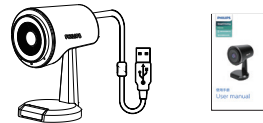

Overview

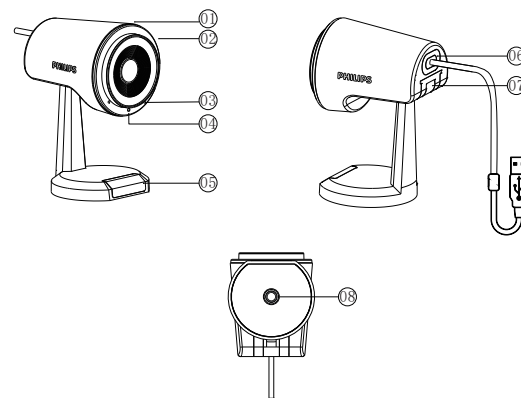

- 01 Metal cover
- 02 Lens frame
- 03 Microphone
- 04 Status indicator
- 05 Silicone non-slip mat
- 06 USB cable
- 07 Rotation axis
- 08 Nut

Settings

Product installation

Support external mounting options:

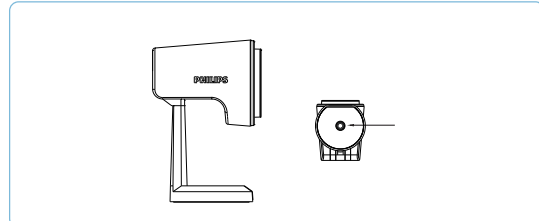

The camera position can be adjusted according to the individual needs.:

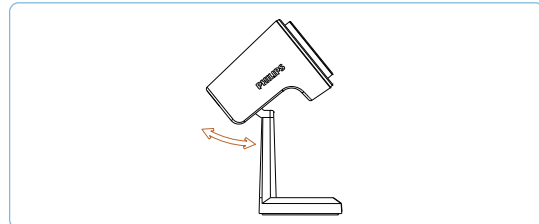

Flexible mounting possible dependent on the type & size of the monitor:

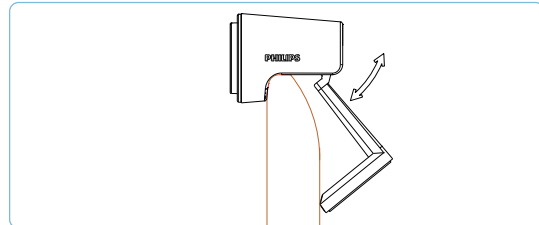

Set up with additional microphones

- When used alone, PSE0510 can be connected to a computer by cables.
- PSE0510 can also be used together with additional microphones to improve audio quality (Philips PSE0400).

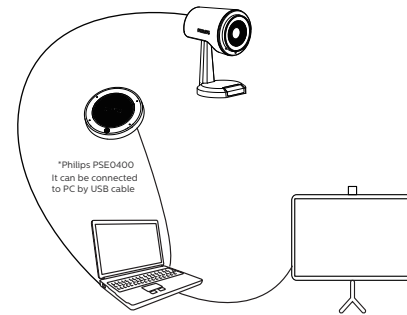

Reminder

- To get the Smart Meeting software, please download: download.szgps.net/SmartMeeting/SmartMeeting.exe
- To know more about operations, please visit: <http://www.jwd-dvr.com/service/download.html>

Service Service Service GUARANTEE

This guarantee card is valid in china. This guarantee card should be owned by The USER.

此保用卡在中国适用，用户请保留此卡。



This product is made of high quality material and great care has been taken in its manufacture. It is designed to give good performance provided it is properly operated and maintained. The product is sold subject to the understanding that if any defect in manufacture or material shall appear within 12 months, the warranty period is subject to country Consumer Law, Jingwah Digital Service will arrange for such defect to be rectified without change under the following warranty items and conditions.

Warranty Terms and Conditions:

The defect is not due to use of the product for other than domestic purposes, or an incorrect voltage, or use of improper accessories, or contrary to operating instructions, or to accidental damage (whether in transit or otherwise), misuse, neglect or inexact repair, or incorrect installation, or the product is excessively used for improper purposes other than daily consumption, or accessories belonging to the product, transportation.

Present this warranty card and sales invoice when demanding service from Philips authorized service centres.

User's Name: 用户姓名	Model No: 型号
Address: 地址	Serial No: 机身编号
Tel.No: 电话	Product Place: 产地
Post Code: 邮编	

Company Seal: 购买商品印章	Shop name and address: 购买商名称及地址
Date of Purchase: 购买日期	Invoice No: 发票号
	Tel.No/Post Code: 电话/邮编

Product Service Hotline: 400 800 7890



Specifications subject to change without notice.

Trade marks are the property of Royal Philips or their respective owners.

© 2021 Speech Processing Solutions GmbH. All rights reserved. Philips and the Philips' shield emblem are registered trademarks of Koninklijke Philips N.V. and are used by Speech Processing Solutions GmbH under license from Koninklijke Philips N.V. All trademarks are the property of their respective owners.

Document version 1.0, 2021-5-11